

MATERIAL HANDLING PRODUCTS

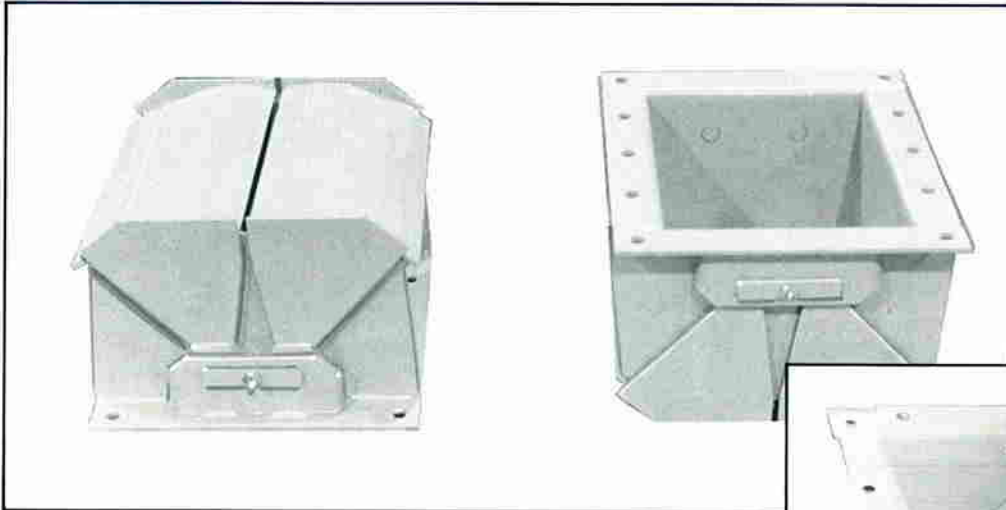

FOR BULK MATERIALS:

STONE, SAND, GRAVEL, LIMESTONE, COAL OR ANY MATERIALS WHICH ARE HANDLED ON A CONVEYOR.



Double Clamshell Gate

Features outboard pin support for longer gate life. These low-profile Clamshell Gates feature clam gate halves joined by gears rather than links to reduce the number of wearing parts. They are designed with an outboard support for locked horizontal pin placement. Since the pin cannot rotate, pin and bushing wear is greatly reduced. Wear is directed to a pin and bushing that are easily and inexpensively replaced. The porous bronze bushing is oil impregnated for the life of the

bushing. As a result, the replaceable bushing and pin never require lubrication. Single clamshell and tunnel gates are also available.

Gate Accessories

- Air Cylinder Kit
- Valves
- Mounting Frame
- Air Line Lubricators
- Moisture Traps
- Regulators
- Other Accessories Available

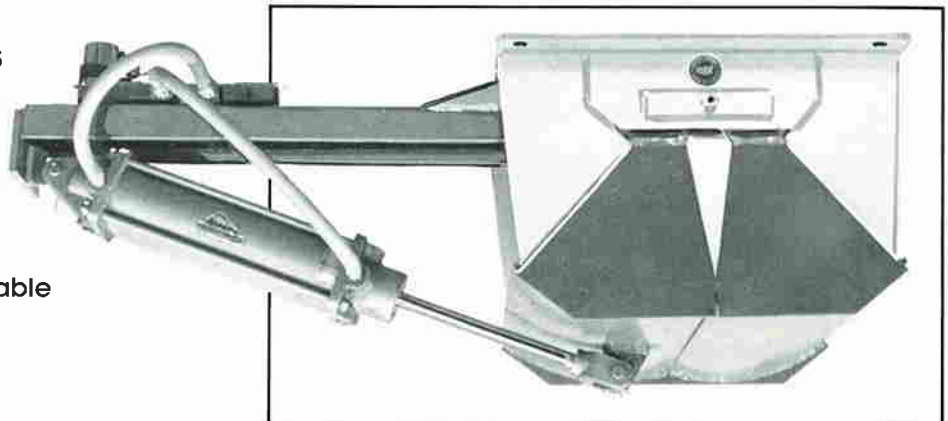

Electric Turnhead

High rotation rate improves system efficiency. The Electric Turnhead distributing spout features high rotation capabilities to reduce or eliminate material gapping on belts. It can make one revolution in less than 10 seconds providing extreme system efficiency. The Turnhead is designed for simple attachment and replacement of chutes and $\frac{3}{16}$ " AR steel liners. Other features include a totally enclosed fan-cooled motor with automatic electric brake, turnhead opening of 30" x 30", and adjustable position limit switches wired to a common junction box.

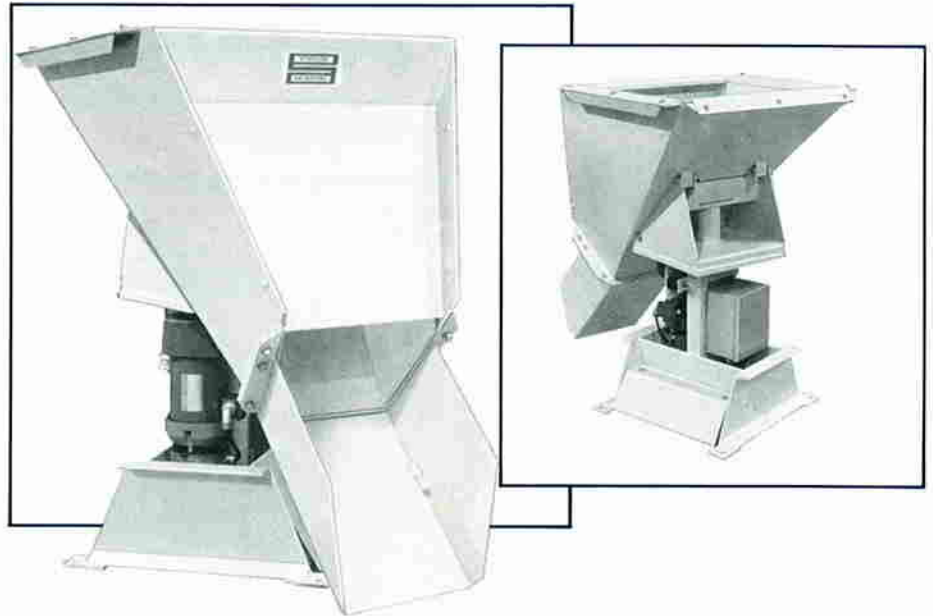

Super Charger



The ultimate control for multiple material handling operations. The Super Charger is a flexible programmable controller capable of controlling four to eight bin compartments with any number of silos and multiple gates. It is designed to track belt speeds, turnhead position and

rotation speed and all gate functions to maximize system efficiency and reduce material gaps.

Other features include plug-in memory module, priority "hunt & seek" next material, automatic bin top off, automatic shut down, "watch dog" safeguard features and more. The SuperCharger is custom engineered to plant requirements but can be retrofitted to existing controls.

Level Signals

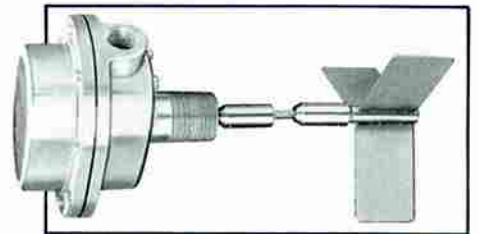

For dependable, long lasting material detection. This mechanical Level Signal is one of the most dependable devices for detecting material demand and cut-off. Available in an easy-to-assemble kit, it includes a rotary paddle power pack, flexible shaft coupling, high strength fiberglass paddle, exclusive lower bearing shaft guard, and adjustable mounting bracket.

190 Simmons Ave., Pewaukee, WI 53072
Phone: 414/691-3100 • Telex: 297-975
FAX: 414/691-3184

MIX
Mixer Systems, Inc.